



## Multi-speed switch CDP2/10

### Use

- Speed on/off switch and speed changeover for multi-speed fans.

### Design

- Casing made of high-quality plastic.
- Wall flush mounting.
- IP 20 ingress protection rating.

### Control

- Direct fan speed switching.

### Mounting

- Wall mounting in a flush mounting box.
- Suitable for installation in standard electric junction boxes.

### Specifications

Parameters	CDP-2/10
Max. supply power, 50/60 Hz [V]	250
Max. load current [A]	10
Cable cross section [mm <sup>2</sup> ]	from 0.35 up to 0.75
Operating temperature range [°C]	from -10 up to +45
Operating humidity range [%]	From 5 up to 80 (no condensation)
Service life	100 000 switching operations
Ingress Protection	IP20
Weight [g]	98

### Wiring diagram

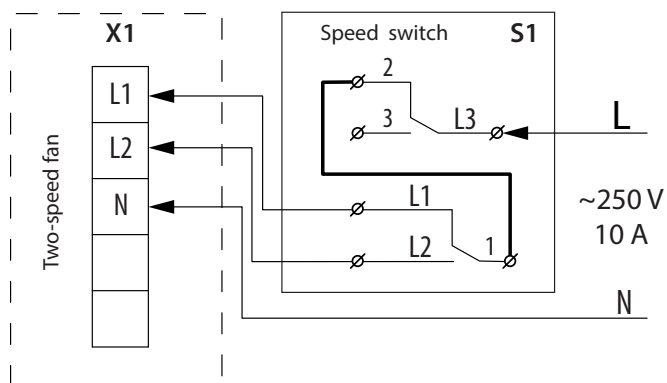

### Control

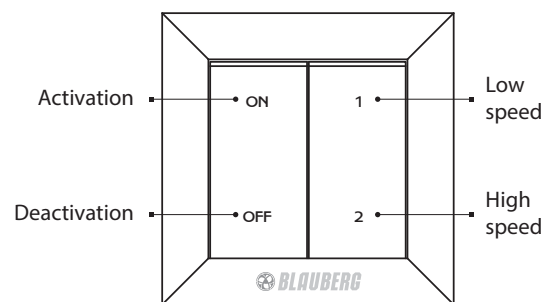

### Overall dimensions, mm

